

# IBM OEM STORAGE PRODUCTS

## WDA S260 & 2120

### *FEATURES*

- 63/126MB formatted capacity (512 bytes/sector)
- AT standard interface- Integrated controller
- IBM PC-AT Task File Architecture
- 1:1 interleave
- 1,7 Run-Length Limited (RLL) encoding
- 32KB Read look-ahead buffer
- Self diagnostics on power up
- Automatic retry and data correction on read errors
- No preventative maintenance required
- Media data transfer rate: 15.1 Mbits/Sec
- Closed loop actuator servo (embedded sector servo)
- Rotary voice coil actuator- Automatic actuator lock
- Dedicated head landing zone
- Average seek time = 18.5 mS (WDA-260)  
16.5 mS (WDA-2120)
- All axis (6 directions) mounting permitted

### *PERFORMANCE*

#### *WDA-S260    WDA2120*

Media Read/Write data Transfer--rate in Mbits/Sec.	15.1	
Rotational speed	3600 RPM	
Average Latency	8.3mS	
Controller overhead (ave)	1.0mS	
Seek times (in mS)		
Single Track	5.0	5.0
Average Length	18.5	16.5
Full Length	29.5	29.5
Power On to Drive Ready	7 Sec (ave)	
Power Off to Spindle Stop	5 Sec (max)	

### *DATA ORGANIZATION*

<i>Physical Layout</i>	<i>WDA-S260</i>	<i>WDA-2120</i>
Bytes per Sector	512	512
Total Data Sectors	123552	247104
Total Data Bytes	63,258,624	126,517,248
Sectors per Track	50	50
Sectors per Cylinder	99	198

Spare Sectors per Cylinder	1	2
Numbers of Data Heads	2	4
Numbers of Disks	1	2

<i>Logical Layout</i>	<i>WDA-S260</i>	<i>WDA-2120</i>
Logical Heads	8	15
Sectors/Track	17	17
Logical Cylinders	909	969
Data Bytes	63,225,856	126,382,080

### ***DC POWER REQUIREMENTS***

Supply Voltage (single supply)	+5 Volts	
Voltage Tolerance (incl. Ripple)	+/-250mV	
Ripple (0-20 MHz)	100mVp-p	
Power Supply Current	Logic	Motor
(average value in Amps)		

#### ***WDA-S260***

Spin-up	0.13	0.57
Seek	0.31	0.09
Write	0.31	0.09
Read	0.31	0.09
Idle	0.15	0.09
Standby	0.06	

#### ***WDA-2120***

Spin-up	0.13	0.71
Seek	0.31	0.09
Write	0.33	0.09
Read	0.33	0.09
Idle	0.15	0.09
Standby	0.06	-

Power Consumption (average value in Watts)	WDA-S260	WDA-2120
Spin-up	3.5	4.2
Seek	2.0	2.0
Write	2.0	2.1
Read	2.0	2.1
Idle	1.2	1.2
Standby	0.3	0.3

#### *Notes:*

1. A soft reset is not required to exit 'Standby' mode (the drives can respond to I/F commands while they are in 'Standby').

2. When a 'Sleep' command is issued, the drives go into 'Standby' mode which allows a faster response than from 'Sleep' mode.

***ELECTRICAL INTERFACE***

***Drive Address:***

A jumper fitted to position JP-1 will select drive address 0 (Master). If no jumper is installed, the drive address is 1 (Slave).

***Interface Connector:***

The drive connector is 2mm pitch. AMP, DuPont, and Hirose all make suitable mating connectors.

***Casting:***

Maximum cable length from host system to HDD shall not exceed 18 inches (45.7cm).

**Connector Side View**

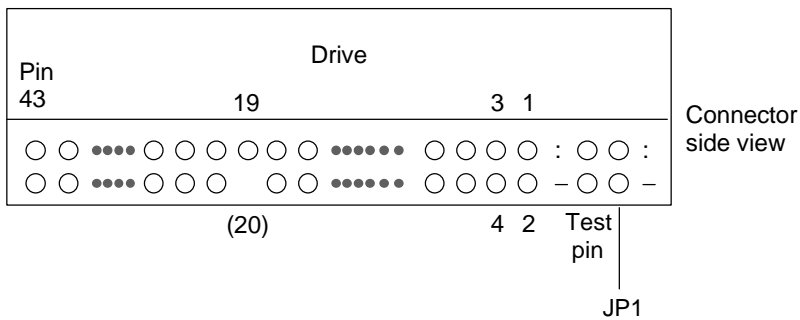

*Figure 1. 44 pin AT connector and jumper pin*

***OPERATING MODE***

***Description:***

**Spin-Up**

The time during which the motor is spinning up from a stopped or power down condition.

**Seek, Read, Write**

Seek, Read, or Write operating modes

**Idle**

Spindle motor and servo system working, all modules (except servo control and interface) are 'sleeping.' Commands can be received and processed immediately.

## Standby

Spindle motor is stopped, all modules (except interface) are 'sleeping.' The drive is waiting for an interrupt and commands can be processed immediately. This is the lowest power dissipation mode.

## SIGNAL DEFINITION

The pin assignments of interface signal are listed as follows:

<b>PIN</b>	<b>Signal</b>	<b>I/O</b>	<b>PIN</b>	<b>Signal</b>	<b>I/O</b>
01	-HRESET	I	02	GND	
03	HD07	I/O	04	HD08	I/O
05	HD06	I/O	06	HD09	I/O
07	HD05	I/O	08	HD10	I/O
09	HD04	I/O	10	HD11	I/O
11	HD03	I/O	12	HD12	I/O
13	HD02	I/O	14	HD13	I/O
15	HD01	I/O	16	HD14	I/O
17	HD00	I/O	18	HD15	I/O
19	GND		(20)	Key	
21	(Resv)		22	GND	
23	-HIOW	I	24	GND	
25	-HIOR	I	26	GND	
27	IORDY	O	28	(Resv)	
29	(Resv)		30	GND	
31	HIRQ	O	32	-HIOCS16	O
33	HA01	I	34	-PDIAG	I/O
35	HA00	I	36	HA02	I
37	-HCSO	I	38	-HCS1	I
39	-DASP	I/O	40	GND	
41	+5V Logic		42	+5V Master	
43	GND		44	-XT/AT	I

### Note:

"O" designates an output from the Drive.

"I" designates an input to the Drive.

"I/O" designates an input/output common.

"PWR" designates a power supply to the Drive.

"(Resv)" designates reserved pins and all of these have to be left unconnected.

### Note:

There are two input pins for the +5 Volt supply, the '+5V LOGIC' line is connected to the internal logic circuits and the '+5V MOTOR' line connects to the spindle motor and associated drivers. This allows the user to reduce power consumption by switching the '+5V LOGIC' supply on and off. The '+5V MOTOR' line should be connected directly into the system power supply to minimize voltage drop caused during motor spin-up, etc.

If this power management option is applied, all signal lines that will be electrically active in the host system while the Drive is disconnected from 5 volt logic supply must be isolated through 'TRI-STATE' drivers.

For normal installation of these drives, connect the '+5V LOGIC' and '+5V MOTOR' lines together.

### ***COMMAND DESCRIPTION***

The following Commands are supported by the Drive:

<b>Commands</b>	<b>(HEX)</b>
Check Power Mode	(E5)
Execute Drive Diagnostics	(90)
Format Track	(50)
Identify Drive	(EC)
Idle	(E3)
Idle Immediate	(E1)
Initialize Drive Parameters	(91)
Read Buffer	(E4)
Read Long (retry)	(22)
Read Long (no retry)	(23)
Read Multiple	(C4)
Read Sectors (retry)	(20)
Read Sectors (no retry)	(21)
Read Verify Sectors (retry)	(40)
Read Verify Sectors (no retry)	(41)
Recalibrate	(1X)
Seek	(7X)
Set Features	(EF)
Set Multiple	(C6)
Sleep	(E6)
Standby	(E2)
Standby Immediate	(EO)
Write Buffer	(E8)
Write Long (retry)	(32)
Write Long (no retry)	(33)
Write Multiple	(C5)
Write Sectors (retry)	(30)
Write Sectors (no retry)	(31)
Write Verify	(3C)

### ***OPERATING ENVIRONMENT***

#### ***Humidity:***

Operating Relative	8% to 90% noncondensing
Nonoperating Relative	5% to 95% noncondensing

***Wet Bulb Temperature:***

Maximum Wet Bulb:

Operating            29.4 degrees Centigrade noncondensing  
Nonoperating        35.0 degrees Centigrade noncondensing

***Elevation:***

Operating Altitude    -100 to 3000m  
Ship/Storage Altitude -300 to 12000m

***Temperature:***

Operating            5 to 55 degrees Centigrade  
Storage              -40 to 65 degrees Centigrade  
Shipping             -40 to 65 degrees Centigrade  
Temperature Gradient 15 degrees Centigrade per hour (maximum)  
(Operating, Storage and Shipping)

***Air Cooling Requirement***

The host system must provide sufficient air flow across the drive to maintain the temperature at less than 60 degrees Centigrade (measured at the center of the drives' top cover).

***Operating and Nonoperating Vibration***

Due to the complexity of this subject, we recommend that users contact the Distributor to discuss how to perform the necessary measurements if they believe this to be an area which requires evaluation.

***Operating Shock***

The drive will withstand (with no hard error) a 10G half-sine wave shock pulse of 11mS duration.

***Nonoperating Shock***

The drive will withstand (with no permanent damage or degradation in performance) a 100G half-sine wave shock pulse of 11mS duration.

***MECHANICAL DATA***

<b>Dimensions</b>	<b>WDA-S260</b>	<b>WDA-2120</b>
Height	12.7 +0.35mm -0.3mm	17.0 +0.35mm -0.3mm
Width	70+/-0.25mm	70+/-0.25mm
Depth	100+/-0.25mm	100+/-0.25mm
Weight	140g maximum	180g maximum

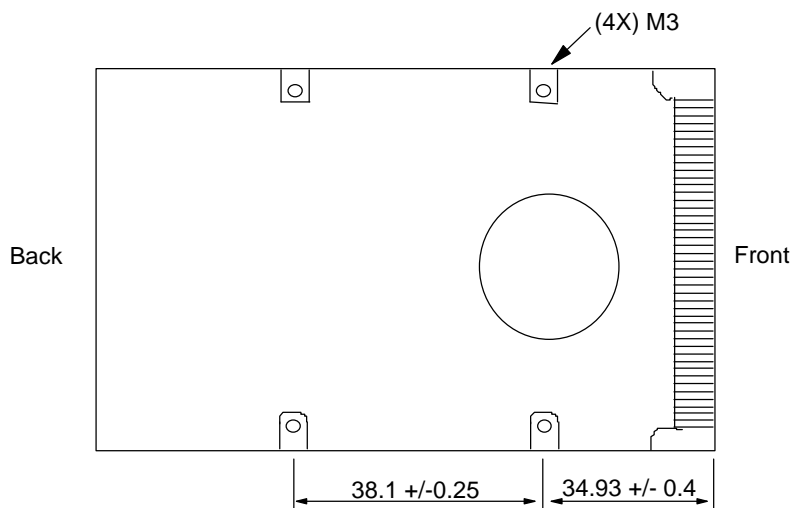
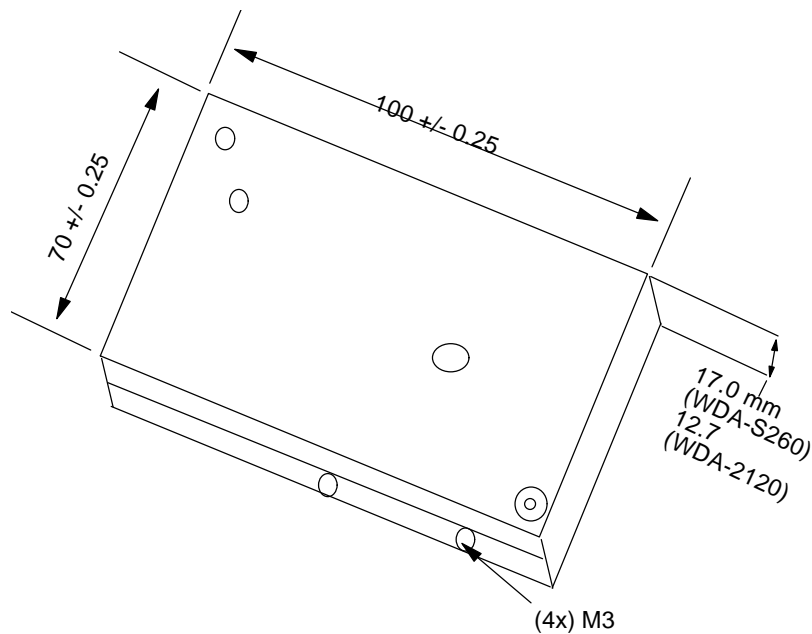

*Note:* Maximum screw lengths must not be exceeded.

***Electromagnetic Compatibility:***

The drive meets the following EMC requirements when installed in the user system and exercised with a random accessing routine at maximum data rate:

- United States Federal Communication Commission (FCC) Rules and Regulations, Part 15, Subject J--Computer Devices, "Class B Limits."
- European Economic Community (EEC) directive #76/889 related to the control of radio frequency interference and the Verband Deutscher Elektrotechniker (VDE) requirements of Germany (GOP).